



# Vehicle History Report

## VEHICLE DETAILS

**Chassis number <sup>1</sup>:** WDC1668751A715491

**Manufacture date:** 2016-02-27

**Make:** MERCEDES BENZ

**Model:** AMG GLS

**Body:** CBA-166874

**Grade:** GLS63 4MATIC

**Engine:** 157

**Drive:** 4WD

**Transmission:** AT

**Title information <sup>2</sup>:**  **Registered** 

**Accident / Repair:**  **No problem** 

**Odometer rollback:**  **No problem** 

**Manufacturer recall:**  **No problem** 

**Safety grade <sup>3</sup>:**  **No data** 

**Contamination risk:**  **No problem** 

This CAR VX Vehicle History Report is based only on Information supplied to CAR VX, LTD and available as of 2026-05-16 18:21:01. Other information about this vehicle, including problems, may not have been reported to CAR VX, LTD . Use this report as one important tool, along with a vehicle inspection and test drive, to make a better decision about your next used car.

## ACCIDENT / REPAIR HISTORY

Problem type	Reported	Date reported	Data source	Details	Airbag
Collision	Not reported				
Malfunction	Not reported				
Theft	Not reported				
Fire damage	Not reported				
Water damage	Not reported				
Hail damage	Not reported				

## ODOMETER READINGS HISTORY

Date reported	Data source	Odometer reading (Km)
2019-02-15	USS Nagoya	39661
2023-05-30	MLIT	70000
2025-05-27	MLIT	108000
2026-05-14	USS Tokyo	126183

## USE HISTORY

<b>Use in the contaminated regions</b> <sup>4</sup>	<b>Radioactive contamination test fail</b> <sup>5</sup>	<b>Commercial use</b>
Not reported	Not reported	Not reported

## DETAILED HISTORY

Event date	Location	Odometer reading (Km)	Data source	Details
2016-02-27			MERCEDES BENZ	Manufactured
2016-05			MLIT	First registration
2019-02-15	Aichi	39661	USS Nagoya	Auctioned
2023-05-30		70000	MLIT	Inspection

2025-05-27	Omiya	108000	MLIT	Inspection
2026-04-06	Omiya		MLIT	Last registration
2026-05-14	Chiba	126183	USS Tokyo	Auctioned

## MANUFACTURER RECALL HISTORY

Date reported	Data source	Affected part	Details
---------------	-------------	---------------	---------

 Not reported

## VEHICLE ASSESSMENT <sup>6</sup>

### Overall Collision Safety Ratings

Driver's seat			Front passenger's seat		
Points	Evaluation	Goal average	Points	Evaluation	Goal average
0		0%	0		0%

\* In order to accurately differentiate between the evaluations of different vehicles, a standard is set based on current technology. Up to 6 points out of 12 is given level 1 and the rest of the range is divided up into equal parts, which are respectively assigned to level 2 (more than 6 points but 7.5 or less), level 3 (more than 7.5 points but 9 or less), level 4 (more than 9 points but 10.5 or less) or level 5 (more than 10.5 points).

### Braking performance tests <sup>7</sup>

Dry road 

Wet road 

## VEHICLE SPECIFICATION

1st gear ratio

2nd gear ratio

3rd gear ratio

4th gear ratio

5th gear ratio

6th gear ratio

Additional notes

Airbag position,  
capacity

<b>Body rear overhang</b>		<b>Body type</b>	SUV
<b>Chassis number embossing position</b>		<b>Classification code</b>	101
<b>Cylinders</b>		<b>Displacement</b>	5460
<b>Electric engine type</b>		<b>Electric engine maximum output</b>	
<b>Electric engine maximum torque</b>		<b>Electric engine power</b>	
<b>Engine maximum power</b>	557ps(410kW)/5250 ~ 5750rpm	<b>Engine maximum torque</b>	77.5kg· m(760N· m)/2000 ~ 5000rpm
<b>Engine model</b>	157	<b>Frame type</b>	
<b>Front shaft weight</b>	1380	<b>Front shock absorber type</b>	
<b>Front stabilizer type</b>		<b>Front tires size</b>	295/40R21
<b>Front tread</b>	1675	<b>Fuel consumption</b>	
<b>Fuel tank equipment</b>	100	<b>Grade</b>	GLS63 4MATIC
<b>Height</b>	185	<b>Length</b>	516
<b>Main brakes type</b>		<b>Make</b>	MERCEDES BENZ
<b>Maximum speed</b>		<b>Minimum ground clearance</b>	
<b>Minimum turning radius</b>	5.7	<b>Model</b>	AMG GLS
<b>Model code</b>	CBA-166874	<b>Mufflers number</b>	
<b>Rear shaft weight</b>	1230	<b>Rear shock absorber type</b>	
<b>Rear stabilizer type</b>		<b>Rear tires size</b>	295/40R21
<b>Rear tread</b>	1695	<b>Reverse ratio</b>	
<b>Riding capacity</b>	7	<b>Side brakes type</b>	
<b>Specification code</b>	17531	<b>Stopping distance</b>	
<b>Transmission type</b>	AT	<b>Weight</b>	2610
<b>Wheel alignment</b>	4WD	<b>Wheelbase</b>	3075
<b>Width</b>	198		

**Date: 2019-02-15, Auction: USS Nagoya, Lot #: 58247**

Date:	2019-02-15	Lot #:	58247
Auction name:	<a href="#">USS Nagoya</a>	Region:	Aichi
Make:	MERCEDES BENZ	Model:	GL
Reg. year:	2016	Mileage (km):	39661
Displacement (cc):	5500	Transmission:	AT
Color:	PEARL	Model code:	166874
Result:	available	Auction grade:	4.5
Problem type:	No problem	Problem scale:	None
Contaminated:	No	Airbag:	OK

**Date: 2026-05-14, Auction: USS Tokyo, Lot #: 75294**

Date:	2026-05-14	Lot #:	75294
Auction name:	<a href="#">USS Tokyo</a>	Region:	Chiba
Make:	MERCEDES BENZ	Model:	AMG GL
Reg. year:	2016	Mileage (km):	126183
Displacement (cc):	5500	Transmission:	AT
Color:	PEARL	Model code:	166874
Result:	available	Auction grade:	4
Problem type:	No problem	Problem scale:	None
Contaminated:	No	Airbag:	OK

**PHOTOS AND AUCTION SHEETS**

# 輸入車プライムコーナー

車検 58247	車歴 (自動車以外は記入)	排気量 5460	型式 CBA-166874	評価点 4.5
	初年度登録年月 28/5月	車名 メルセデス・ベンツ	グレード GLS63 AMG 4マフラー	

車検 31年 5月	シフト AT	燃費 S R AW P S カブ TV ナビ ETC
走行 39,661 km	冷房 AAC	セールスポイント 純正ナビ、アルペグV、BOMラ 360カメラシステム レーダーセーフティ 911-マンガンダウンサスペンション オプションレザーシート (メモリー、ヒーター)
外色 パール →	カラー 799	新車登録手数料 (保証書付) 有・無
燃料 ガソリン・軽油・( )	内装色	名義変更期間 月 日
輸入車種 タイマー・並行	ハンドル 左 右	

リサイクル 廃車金 22900円	標準定員 7人	登録料 税関 330 車 435
		車台号 WDC1668751A715491
		シリアル号

- ◎注意事項 (修理・不具合箇所および状態等)
- キルズゴ-キ2 (12個)
  - フロアマット (車内)
  - LEDヘッドライト
  - ETC
  - パワーバックドア
  - ユーザー買取
  - AMGホイール、マフラー
  - 内外装クリーニング済
- ◎検査員報告 (USS使用欄) オクシジェン物
- 取説、キー、後日
- ハンドルスレ
- シートベルトシワ
- 前室キス
- ボディカバン、ホイールキス
- 小キス、小凹
- ルーフレール、モルタン一部キス

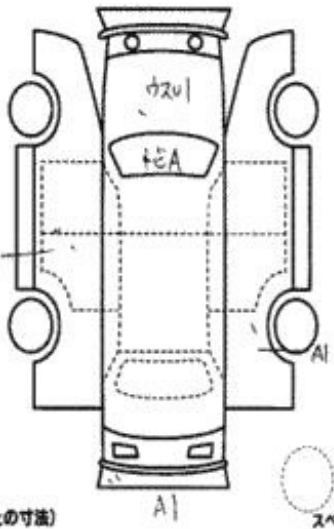

台内寸約 X X (cm)  
 長さ cm 幅 cm 高さ cm (車検証上の寸法)





## 輸入車プライムコーナー

75294	車歴 (前車用以外4位記入)	排気量	型式	評価点 4
	28/5月	5500	CBA-106874	
	初年度年/月	車名	グレード	2WD
		XLBTRAMQ SD	GLS63	<input checked="" type="checkbox"/>
			424.7	内装 B

車検	9年 6月	シフト	AT	燃費	BA <input checked="" type="checkbox"/> BAW <input checked="" type="checkbox"/> PB <input checked="" type="checkbox"/> PW <input checked="" type="checkbox"/>
走行	126183 Km	冷却	AAC	セーレスポイント	
外色	色別	カラー		キ-LSJ- 11-220-ピン	
内色	1P-1V	799		368カク 197-ゲート	
燃料	ガソリン・軽油( )	内装色		レ-9-E-771 スP3キ-	
輸入年月	輸入区分	ハンドル			
	ロー-直行	右			

リサイクル 預託金	22900 円	乗車定員	人	重量	kg	303	と	2914
○注意事項 (検査・不具合箇所および状態等)				車台	WDC1668751A715491			
				シリアル				

○検査員報告 (USS使用欄)

11.12.16.17.18.19.20

11.12.16.17.18.19.20

11.12.16.17.18.19.20

11.12.16.17.18.19.20

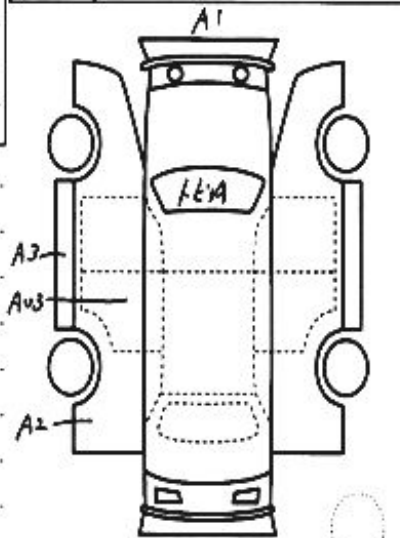

【脚台内寸】的	x	x	(cm)
長さ	cm	幅	cm
		高さ	cm

← (取付位置上の寸法) スベア

**<sup>1</sup> Chassis number** – a unique identification number of the vehicle in Japan (same as VIN in the USA or Europe)

**<sup>2</sup> Title information:**

Registered – qualified for driving in Japan

Deregistered Temporarily – not qualified for driving in Japan, usually a temporary title during the ownership change

Deregistered Completely – not qualified for driving in Japan, the vehicle is determined to be scrapped

Deregistered to Export – not qualified for driving in Japan, the vehicle is determined to be exported

**<sup>3</sup> Determining the overall collision safety performance evaluation** – For the driver's seat, the results of the full-wrap frontal collision test, offset frontal collision test, and side collision test are added together and evaluated to 6 different levels. For the Frontal passenger's seat, the results of the full-wrap frontal collision test and the side collision test (results for the driver's or the front passenger's seat are used) are added together and evaluated to 6 different levels.

Regular vehicle inspection – All vehicles in Japan must undergo regular vehicle inspections (shaken). New cars need to be tested after three years, and then vehicles must be tested every two years thereafter. A vehicle inspection (shaken) is compulsory for all vehicles with an engine size over 250cc. It ensures that all vehicles on the road are properly maintained and safe to drive. The test also checks that vehicles have not been illegally modified; if they are found to have been modified, they are not allowed on the road.

**<sup>4</sup> Use in the contaminated regions** – The Fukushima Daiichi nuclear disaster was a catastrophic failure at the Fukushima I Nuclear Power Plant on 11 March 2011, resulting in a meltdown of three of the plant's six nuclear reactors. As a result, some areas in the following prefectures were contaminated: Fukushima, Miyagi, Ibaraki, Tochigi.

**<sup>5</sup> Radioactive contamination test** – radioactive contamination inspection that was started in July 2011 as a preventive measure for exporting contaminated vehicles from Japan. The inspection is being conducted since in all sea ports of Japan under the supervision of The Japan Harbor Transportation Association (JHTA).

MLIT – Ministry of Land, Infrastructure, Transport and Tourism.

**<sup>6</sup> Japan New Car Assessment Program** – the Ministry of Land, Infrastructure, Transport and Tourism (MLIT) and the National Agency for Automotive Safety & Victims' Aid (NASVA) have taken measures for safety, one of which is to assess commercially available vehicles through a variety of safety performance tests and release the resulting information compiled into the "New Car Assessment Program". The objective of Japan New Car Assessment Program is to increase the use of safe automobiles by providing an environment in which users can easily select such vehicles. This also promotes the development of safer vehicles by automobile manufacturers. Neck injury protection for rear-end collision performance test, rear seat passenger's protection for frontal collision performance test, rear passenger's seat belt usability evaluation test and seat belt reminder for passengers evaluation test are started in FY2009.

**<sup>7</sup> Braking Performance Tests** – Braking performance is determined by the shortness of the distance in which a vehicle can stop and the stability of the vehicle at the time of braking. This test is performed under wet and dry road conditions for a vehicle which has both a driver and a front passenger. The distance it takes for the vehicle to stop and the stability of the vehicle at the time of braking is evaluated for when the vehicle is stopped abruptly while traveling at a speed of 100km/h. The stopping distance and vehicle speed have been measured by using GPS since FY2009.

CAR VX, LTD DEPENDS ON ITS SOURCES FOR THE ACCURACY AND RELIABILITY OF ITS INFORMATION. THEREFORE, NO RESPONSIBILITY IS ASSUMED BY CAR VX, LTD OR ITS AGENTS FOR ERRORS OR OMISSIONS IN THIS REPORT. CAR VX, LTD FURTHER EXPRESSLY DISCLAIMS ALL WARRANTIES, EXPRESSED OR IMPLIED, INCLUDING ANY IMPLIED WARRANTIES OF MERCHANTABILITY OR FITNESS FOR A PARTICULAR PURPOSE.

© 2014-2026 Car VX Limited. All rights reserved.